

Crossed Roller Bearing Positioners

Parker precision crossed roller stages provide controlled, precise point-to-point positioning along a linear axis. Stages are comprised of two basic components: a precision linear crossed roller slide which serves as a linear bearing and guide, and a drive mechanism which accurately moves and positions the slide top along the linear axis. Crossed roller positioning stages offer exceptional load carrying capability, approximately 2 to 2 1/2 times that of comparably sized ball bearing stages. Additionally, crossed roller stages provide up to five times the life expectancy of the ball bearing stages without degradation of performance. Parker crossed roller stages are rated for over 100 million inches of travel at specified load.

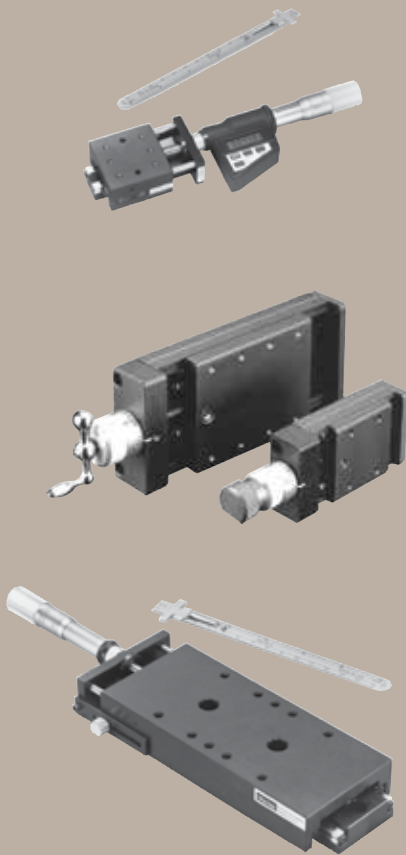

Contents

90-91	Overview
92-96	1.75" (44,5 mm) Wide
97	1.97" (50,0 mm) Wide
98-101	2.62" (66,5 mm) Wide
102	2.95" (75,0 mm) Wide
103	3.94" (100,0 mm) Wide
104-107	5.00" (127,0 mm) Wide
108-110	6.00" (152,4 mm) Wide
111-114	Performance Curves

Crossed Roller Bearing Positioners

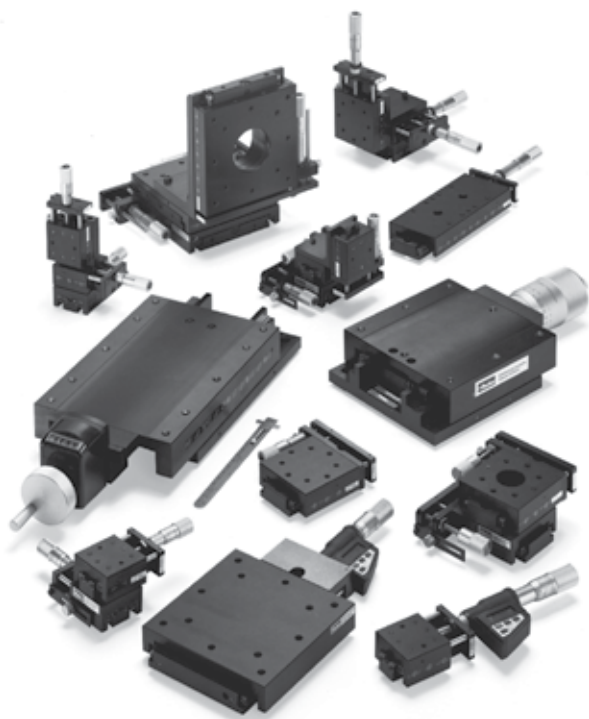

- Precision Quality
- Budget Friendly
- Largest Selection
- Easy multi-axis configuration
- No maintenance
- Vacuum preparation and custom options

Crossed Roller Positioner Design Principles

Crossed roller positioning stages offer exceptional load carrying capability, approximately 2 to 2 1/2 times that of comparably sized ball bearing stages. Additionally, crossed roller stages provide up to five times the life expectancy of the ball bearing stages without degradation of performance. Parker crossed roller stages are rated for over 100 million inches of travel at specified load. Three types of drive mechanisms are available: a fine screw, a micrometer, and a differential screw. The fine screw is used for fine resolution positioning. The micrometer is used whenever a position readout is required. The differential screw is used for applications requiring extremely fine resolution positioning. Crossed roller positioning stages are available in a straight stage/drive configuration as well as a side-drive configuration.

The linear positioner operates in a simple manner: a bracket which supports the drive screw is attached to the slide base. The end of the drive screw rests against the end of the moveable top. There are two extended springs “pulling” the slide top toward the screw so that the top will always be held firmly against the screw end. When the screw is turned clockwise, it advances and pushes the slide top along the linear axis. When turned counter clockwise, the screw retracts and the slide top follows because of the spring pressure holding the top against the screw end. The result is a very smooth linear motion, accurately controlled by rotation of the drive mechanism.

Standard Features

Exact manufacturing techniques, combined with demanding quality control standards, permit Parker Daedal to offer precision stages of unsurpassed quality. Selection can be made easily, based on required travel, load, and mounting surface requirements. Stages are available in single or multi-axis configurations (XY, XZ, and XYZ), and all have built-in quality features including:

- Aluminum/steel construction
- Low friction linear adjustment with no backlash or side play
- Factory preloaded to provide dynamic stability and minimum runout
- Both top and bottom mounting surfaces are precision machined to provide micro-flat mounting surfaces
- Locking screw to positively lock stage without affecting position
- Straight line accuracy of 0.00008 in/in of travel
- Selectable drive mechanisms: Micrometer (Imperial or metric), Fine screw (64 pitch), Differential screw, Digital micrometers (Imperial and Metric)

Digital Micrometers

The 1.0” (25 mm) travel micrometer provides an LCD readout to 0.00005 in (0,001 mm) resolution and features incremental and/or absolute positioning modes and automatic shutdown to conserve the integral battery. The battery will power the unit for 500 hours of use. The 2.0” (51 mm) micrometer is accurate to ± 0.0001 in (± 2 microns) with a resolution and LCD reading to 0.00005 in (1 micron). The batteries will power the unit up to 5,000 hours.

How to Order

Use the overview chart on the following page to select the appropriate crossed roller positioner. Refer to the individual specifications page for complete performance and mechanical specifications. To order crossed roller bearing positioners, use the model number corresponding to the specific size and travel length selected. A variety of modifications to standard models are available to meet custom requirements. Contact our application engineering department with your design specifications.

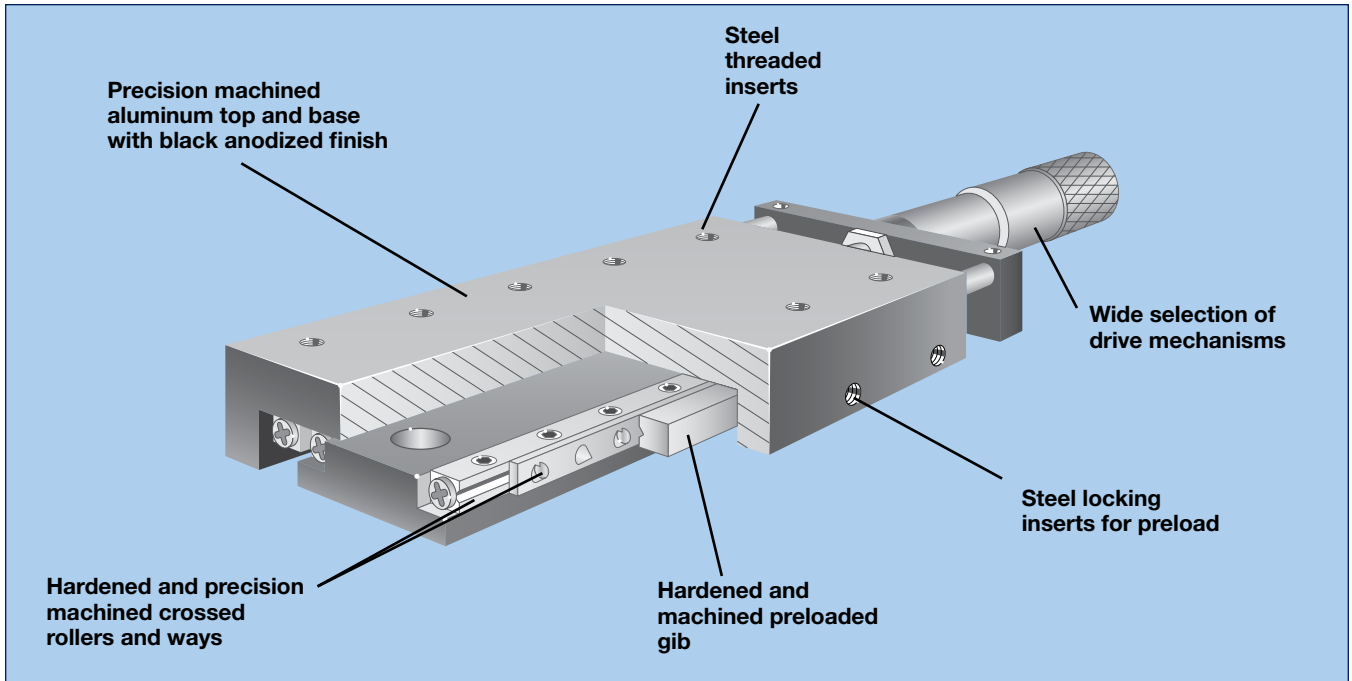

Crossed Roller Positioners

Series	Width in (mm)	Travel		Normal Load		Drive Orientation		Mounting		Page
		in	(mm)	lbs	(kg)	Center	Side	Imperial	Metric	
CR4000	1.75 (44,5)	1.00	(25,4)	81	(37)	•	•	•		92-94
CR4100				81	(37)	•		•		95-96
CR4200				121	(55)	•		•		95-96
CR4300				131	(59)	•		•		95-96
SC050	1.97 (50,0)	0.98	(25)	175	(80)	•			•	97
SK050		1.97	(50)	263	(119)	•			•	
		2.95	(75)	351	(159)	•			•	
CR4500	2.62 (66,5)	1.00	(25,4)	111	(50)	•	•	•		98-99, 101
CR4600				151	(69)	•		•		100-101
CR4700				201	(91)	•		•		100-101
CR4800				251	(114)	•		•		100-101
SC075	2.95 (75,0)	0.98	(25)	351	(159)	•			•	102
SK075		1.97	(50)	439	(199)	•			•	
		2.95	(75)	527	(239)	•			•	
SC100	3.94 (100,0)	0.98	(25)	439	(199)	•			•	103
SK100		1.97	(50)	527	(239)	•			•	
		2.95	(75)	614	(278)	•			•	
		3.94	(100)	702	(318)	•			•	
CR4400	5.0 (127,0)	1.00	(25,4)	201	(91)	•	•	•		104-107
		2.00	(50,8)	201	(91)	•	•	•		104-107
CR4900	6.0 (152,4)	1.00	(50,8)	423	(192)	•		•		108-109
		2.00	(50,8)	423	(192)	•		•		108-109
		4.00	(100,0)	423	(192)	•		•		110
		6.00	(150,0)	719	(326)	•		•		110
		8.00	(200,0)	1052	(477)	•		•		110
		10.00	(250,0)	1395	(633)	•		•		110
	12.00	(300,0)	1735	(786)	•		•		110	

CR4900 Series

Specifications	
Travel:	1.0 – 2.0 in
Size:	
Width	6.00 in
Length (mid-travel)	9.59 – 11.94 in
Height	2.00 in
Load:	
Normal	423 lbs
Thrust T_a (Std. thimble)	30 lbs
Thrust T_b (Std. thimble)	5 lbs
Thrust T_a (Large thimble)	50 lbs
Thrust T_b (Large thimble)	5 lbs
Moment – Yaw, Pitch, Roll	See page 114
Straight line accuracy:	0.00008 in/in of travel
Micrometer graduations:	
Standard thimble	0.001 in or 0,01 mm
Large thimble	0.0001 in or 0,002 mm
Weight:	7 lbs/axis
Z-Axis bracket options: (See page 124-127)	4990-04
Construction:	Aluminum top and base/ steel crossed roller bearings
Mounting surface:	Precision machined
Finish:	Black anodize



Standard thimble with optional position lock (left), and large thimble (right). To order the optional lock, add -L to the model number selected from the chart below.

Consult factory for critical dimension concerns.

Dimensions Inches

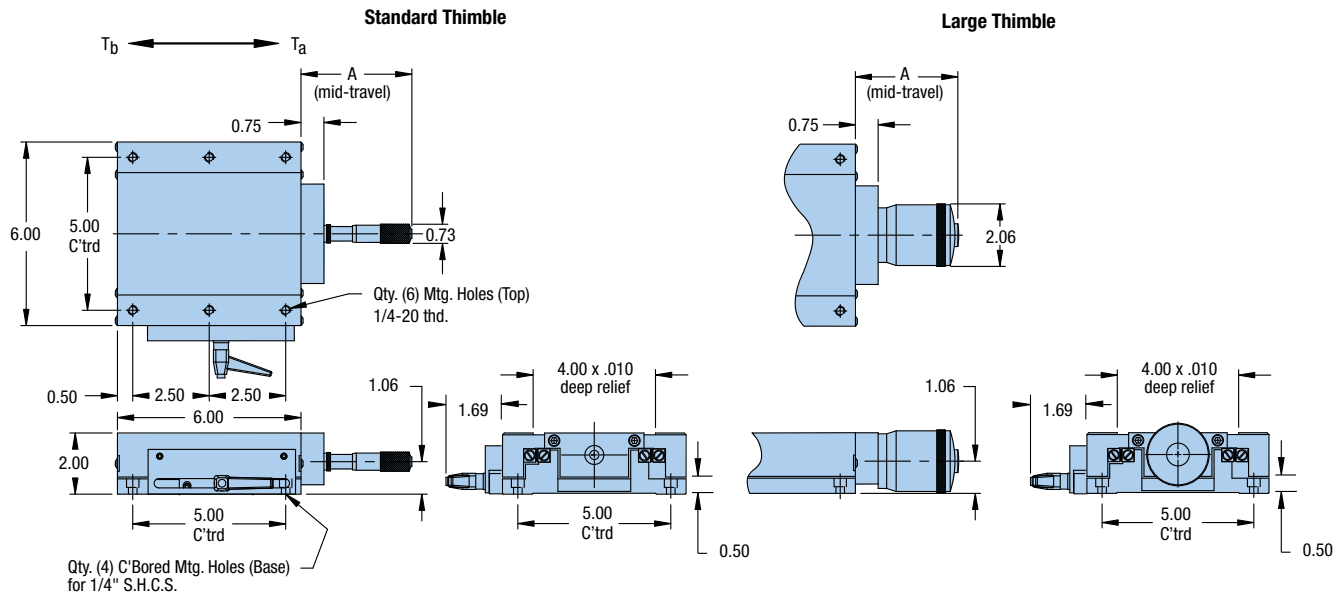

Drive Mechanism	Travel	Standard Thimble Size			Large Thimble Size		
		Model	Graduations	A – in	Model	Graduations	A – in
Imperial Micrometer	1.0 in	CR4914	0.001 in	3.59	CR4910	0.0001 in	4.44
	2.0 in	CR4915	0.001 in	5.11	CR4911	0.0001 in	5.94
Metric Micrometer	25 mm	CR4916	0.01 mm	3.59	CR4912	0.002 mm	4.44
	50 mm	CR4917	0.01 mm	5.11	CR4913	0.002 mm	5.94



CR4900-DM Series

Specifications

Travel:	2.0 in
Size:	
Width	6.00 in
Length (mid-travel)	13.93 in
Height	2.00 in
Load:	
Normal	423 lbs
Thrust T_a	50 lbs
Thrust - T_b	5 lbs
Moment - Yaw, Pitch, Roll	See page 114
Straight line accuracy:	0.00008 in/in of travel
Micrometer graduations:	
Large thimble	0.00005 in or 0,001 mm
Weight:	8 lbs/axis
Z-Axis bracket options: (See page 124-127)	4990-04
Construction:	Aluminum top and base/ steel crossed roller bearings
Mounting surface:	Precision machined
Finish:	Black anodize



Digital micrometer positioner shown with optional position lock. To order the optional lock, add -L to the model number selected from the chart below.

Consult factory for critical dimension concerns.

Crossed Roller Positioners

Dimensions Inches

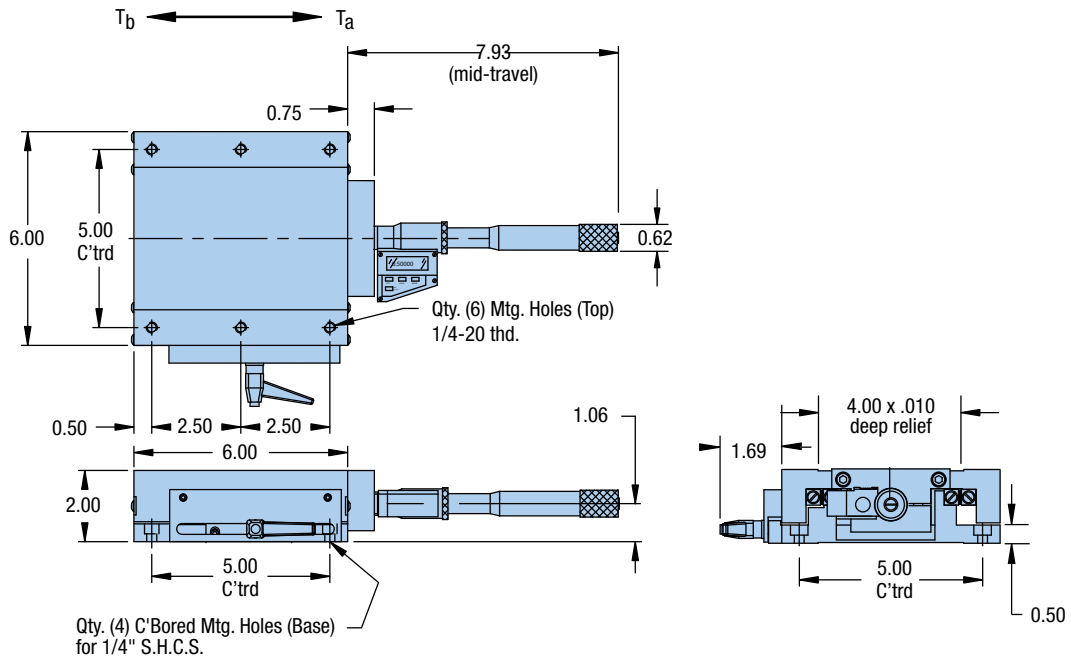

Model	
Imperial Mounting	CR4911-DM

CR4900 Series (Leadscrew Drive)

Specifications	
Travel:	4.0 – 12.0 in
Size:	
Width	6.00 in
Length (mid-travel)	10.04 – 23.04 in
Height	2.00 in
Load:	
Normal	423 – 1733 lbs
Thrust T_a	30 lbs
Thrust – T_b	30 lbs
Moment – Yaw, Pitch, Roll	See page 114
Straight line accuracy:	0.00008 in/in of travel
Readout graduations:	0.001 in or 0,01 mm
Weight:	4 – 12 lbs/axis
Z-Axis bracket options: (See page 124-127)	4990-04/-12
Construction:	Aluminum top and base/ steel crossed roller bearings
Mounting surface:	Precision machined
Finish:	Black anodize



Leadscrew drive positioner with readout (left); positioner with no readout and optional position lock (right). To order the optional lock, add -L to the model number selected from the chart below.

Consult factory for critical dimension concerns.

Dimensions Inches

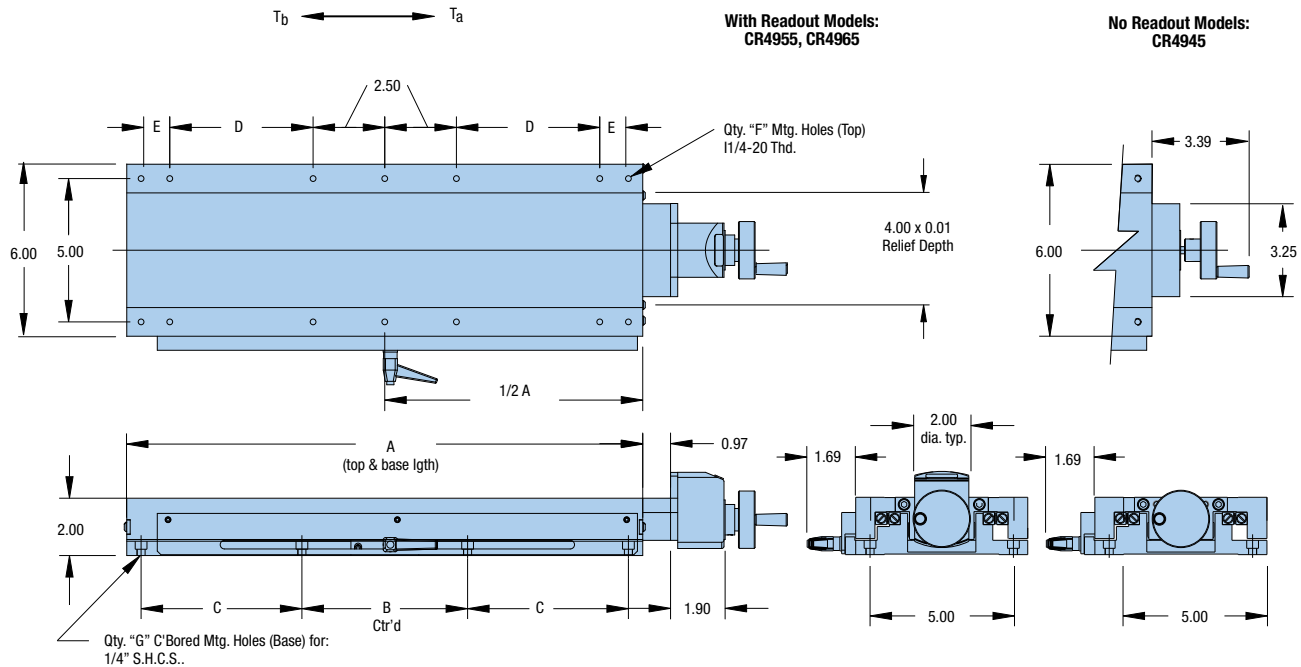

No Readout Model	Imperial Readout Model	Metric Readout Model	Travel	Load	Weight	Dimensions – In (mm)					Qty F	Qty G
						A	B	C	D	E		
CR4945-04	CR4955-04	CR4965-04	4.0 in	423 lbs	4.0 lbs	6.00	5.00	—	—	—	6	4
CR4945-06	CR4955-06	CR4965-06	6.0 in	719 lbs	6.0 lbs	9.00	5.00	1.50	1.50	—	10	8
CR4945-08	CR4955-08	CR4965-08	8.0 in	1052 lbs	8.0 lbs	12.00	5.00	3.00	2.50	—	10	8
CR4945-10	CR4955-10	CR4965-10	10.0 in	1395 lbs	10.0 lbs	15.00	6.00	4.00	2.50	2.00	14	8
CR4945-12	CR4955-12	CR4965-12	12.0 in	1735 lbs	12.0 lbs	18.00	7.00	5.00	5.00	1.00	14	8



Yaw, Pitch, Roll

Yaw & Pitch Roll

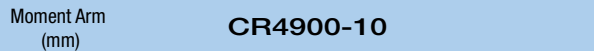
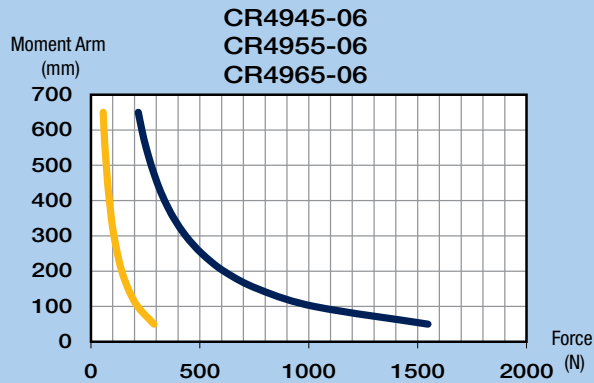
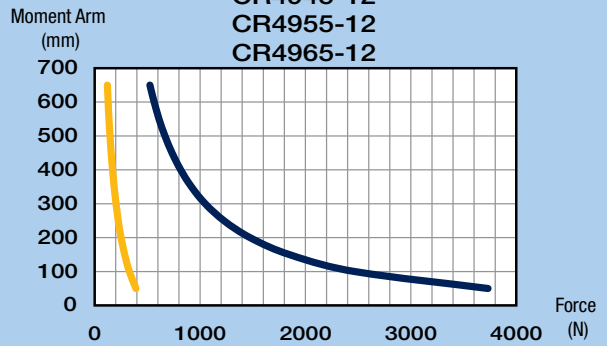
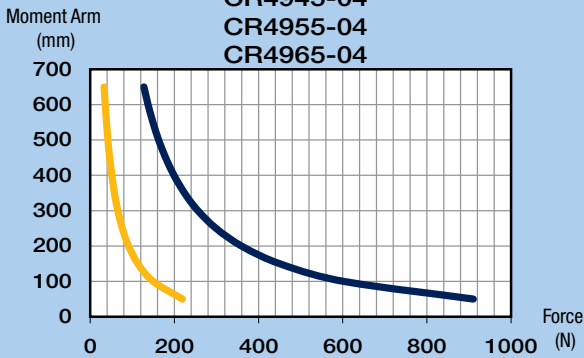
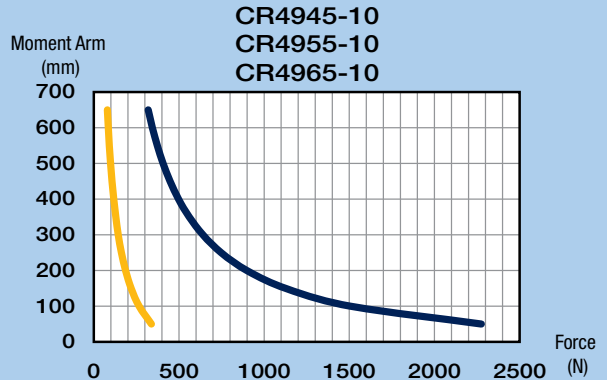
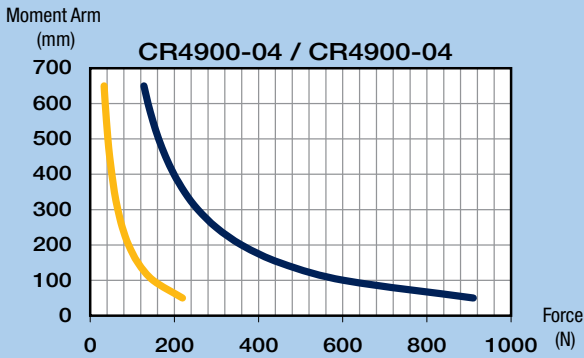
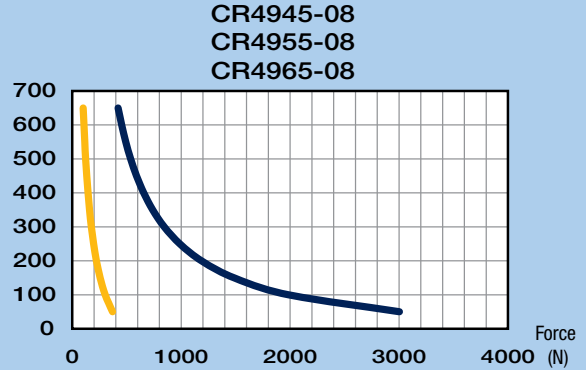
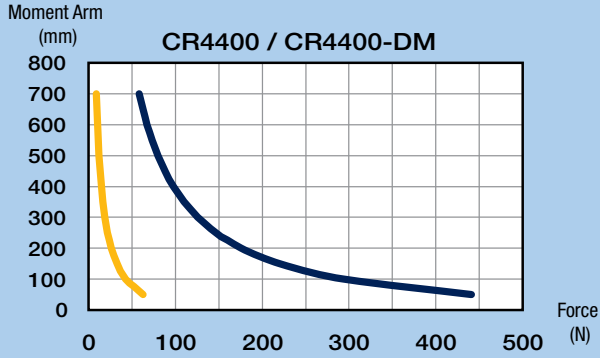

Accessories for Linear and Rotary Positioners



Parker offers a complete line of Z-axis brackets to combine ball bearing and cross roller stages into three axis positioning systems. We also offer drive mechanisms in an assortment of standard and digital micrometer heads, fine adjustment screws, and differential screws. Optical components including beam directors, optical mounts, mirror mounts and optical cells are also available.

Contents

124-127	Z-Axis Brackets
128-129	Micrometer Heads
130-132	Optical Mounts

Z-Axis Brackets

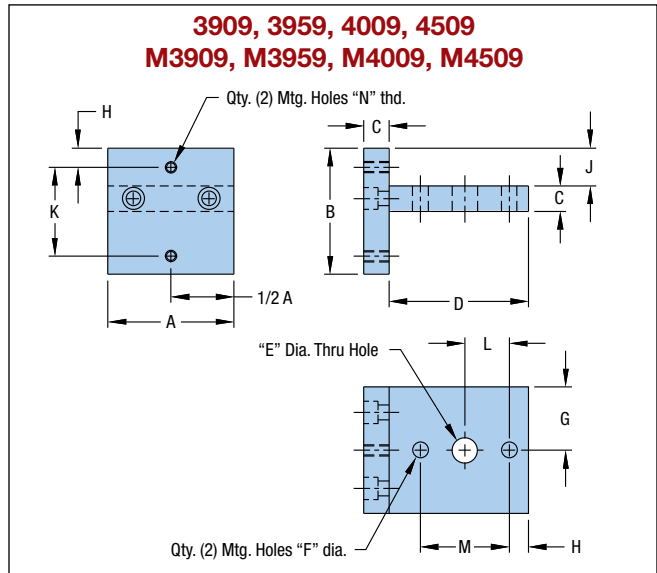

		Dimensions – in (mm)											Thd. N	
	Model	A	B	C	D	E	F	G	H	J	K	L	M	
Imperial	3909	1.25	1.25	0.25	1.38	0.25	0.156	0.62	0.19	0.38	0.88	0.44	0.88	#4-40
	3959	1.25	1.25	0.25	1.38	0.25	0.156	0.62	0.19	0.04	0.88	0.44	0.88	#4-40
	4009	1.75	1.69	0.25	1.88	—	0.156	0.88	0.31	0.63	1.12	—	1.12	#6-32
	4509	2.44	2.62	0.38	2.75	—	0.218	1.22	0.31	0.93	2.00	—	2.00	#10-32
Metric	M3909	(31,8)	(31,8)	(6,4)	(35,1)	(6,4)	(4,0)	(15,7)	(5,9)	(9,7)	(20,0)	(10,0)	(20,0)	M3
	M3959	(31,8)	(31,8)	(6,4)	(35,1)	(6,4)	(4,0)	(15,7)	(5,9)	(1,0)	(20,0)	(10,0)	(20,0)	M3
	M4009	(44,5)	(42,9)	(6,4)	(47,8)	—	(4,8)	(22,4)	(7,3)	(16,0)	(30,0)	—	(30,0)	M4
	M4509	(62,0)	(66,5)	(9,7)	(69,9)	—	(7,3)	(31,0)	(8,4)	(23,6)	(50,0)	—	(50,0)	M6

**3910, 3960
M3910, M3960**

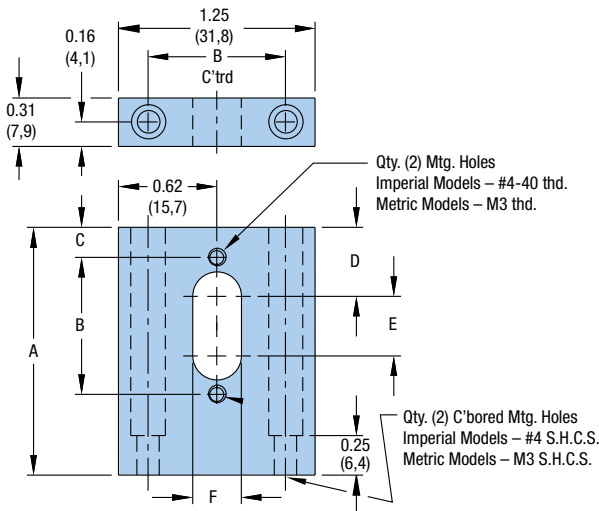

		Dimensions – in (mm)					
	Model	A	B	C	D	E	F
Imperial	3910	1.58	0.88	0.19	0.44	0.38	0.31
	3960	2.33	0.88	0.19	0.44	0.38	0.31
Metric	M3910	(40,1)	(20,0)	(5,9)	(12,3)	(7,1)	(6,4)
	M3960	(59,2)	(20,0)	(5,9)	(12,3)	(7,1)	(6,4)

**4010, 4020
M4010, M4020**

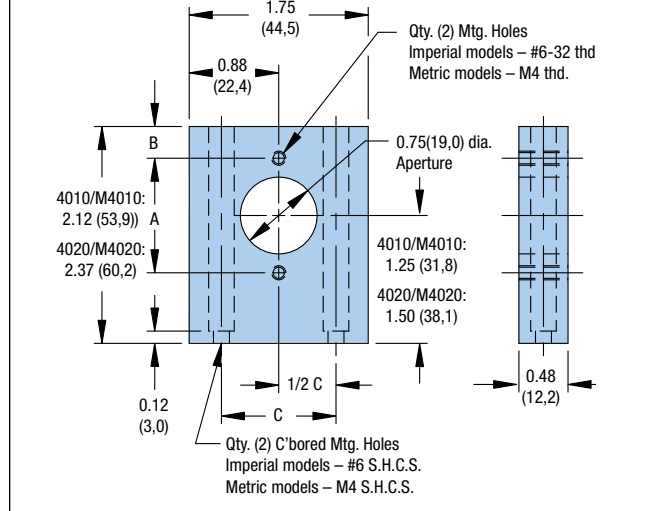

		Dimensions – in (mm)		
	Model	A	B	C
Imperial	4010	1.12	0.31	1.12
Metric	M4010	(30,0)	(7,1)	(30,0)



4059 M4059

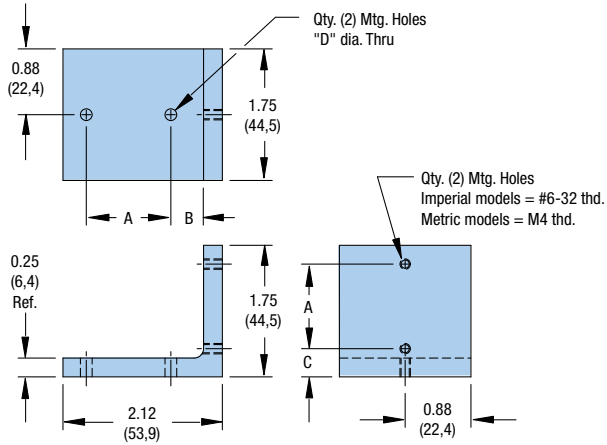

4059A M4059A

For 1.00 inch (25,0 mm) Travel Micrometer Option

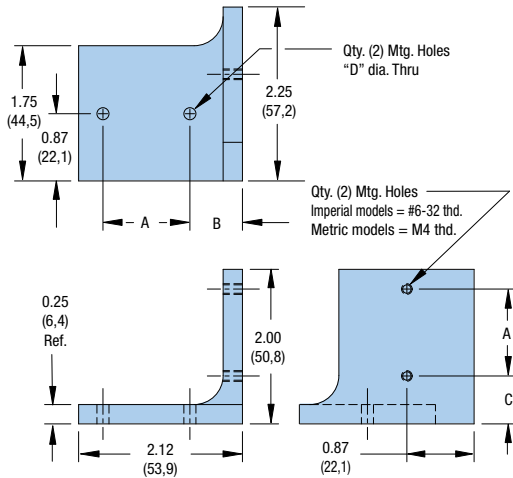

Dimensions - in (mm)					
	Model	A	B	C	D
Imperial	4059	1.12	0.68	0.38	0.16
Metric	M4059	(30,0)	(16,8)	(8,8)	(4,8)

Dimensions - in (mm)					
	Model	A	B	C	D
Imperial	4059A	1.12	0.68	0.62	0.16
Metric	M4059A	(30,0)	(16,8)	(15,2)	(4,8)

4060 M4060

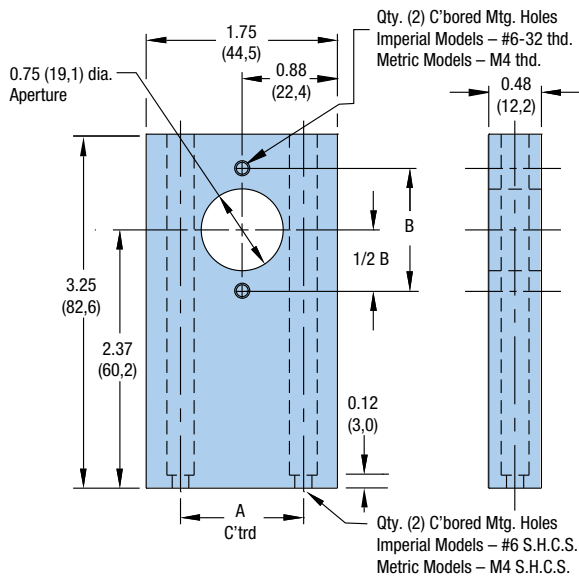

4510 M4510

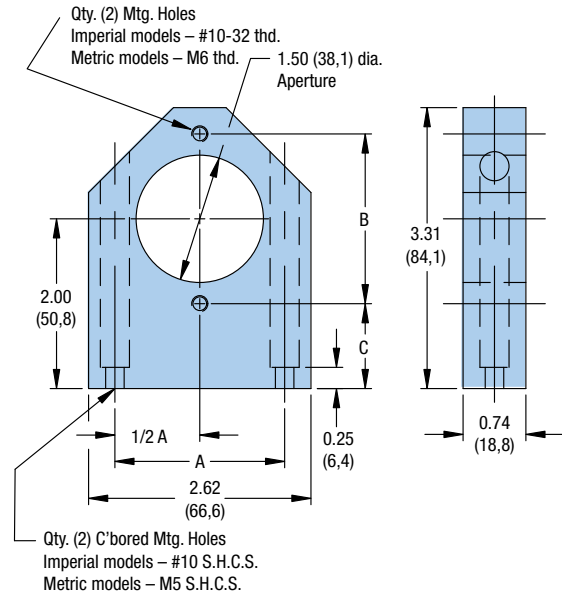

Dimensions - in (mm)			
	Model	A	B
Imperial	4060	1.13	1.13
Metric	M4060	(30,0)	(30,0)

Dimensions - in (mm)				
	Model	A	B	C
Imperial	4510	2.00	2.00	1.00
Metric	M4510	(50,0)	(50,0)	(25,8)

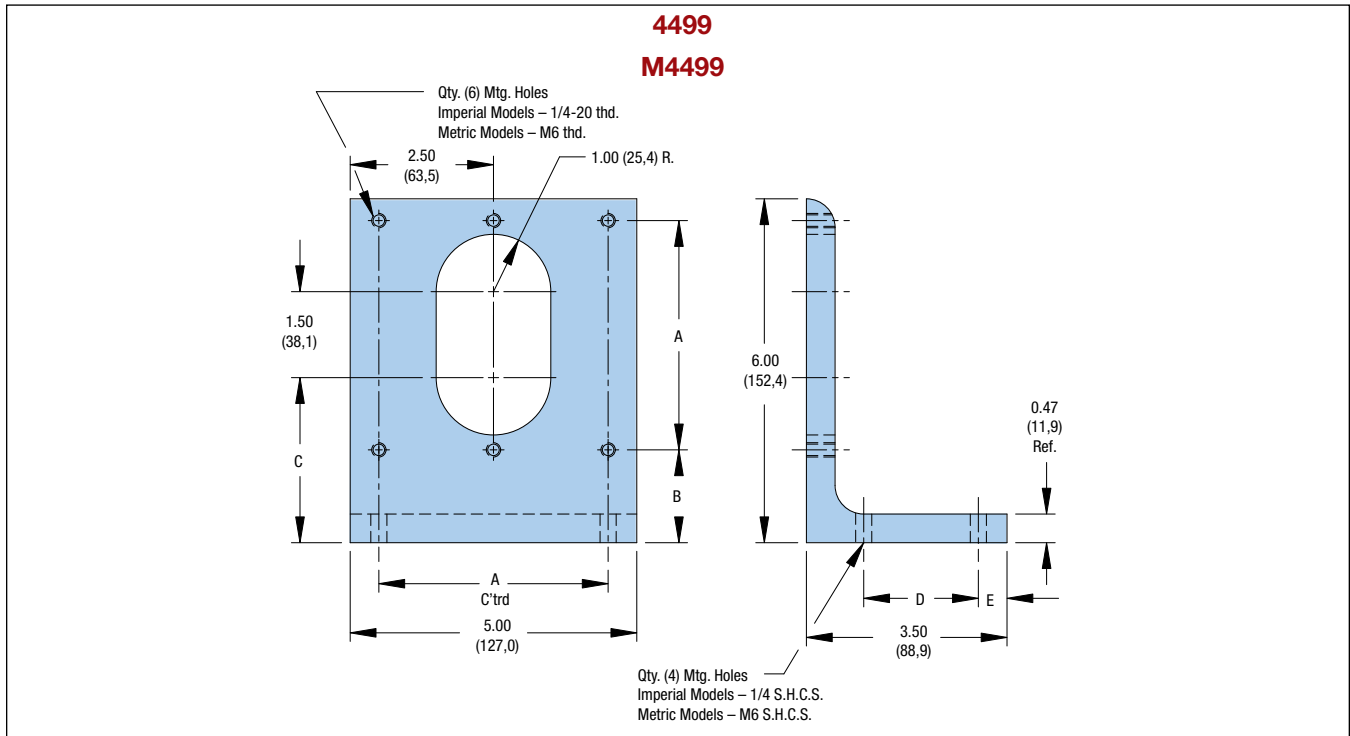

		Dimensions - in (mm)				
	Model	A	B	C	D	E
Imperial	4499	4.00	1.62	2.88	2.00	0.50
Metric	M4499	(100,0)	(40,5)	(71,4)	(50,0)	(13,1)

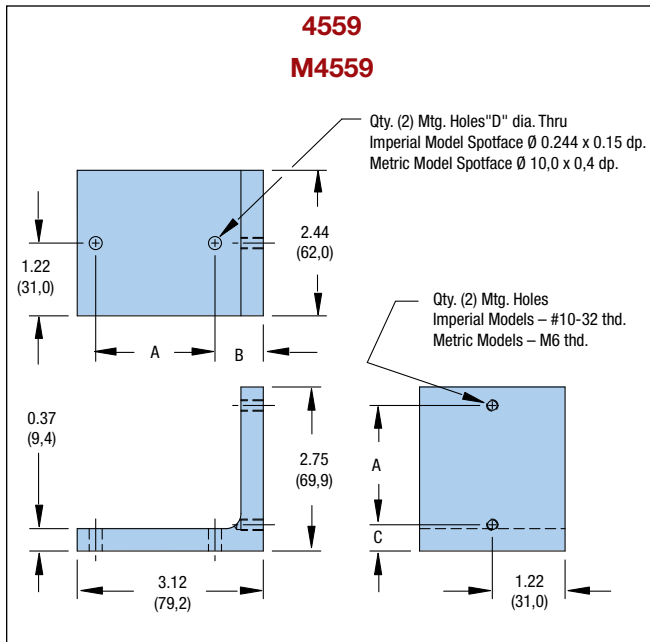

		Dimensions - in (mm)			
	Model	A	B	C	D
Imperial	4559	2.00	0.81	0.44	0.22
Metric	M4559	(50,0)	(20,9)	(11,5)	(5,5)

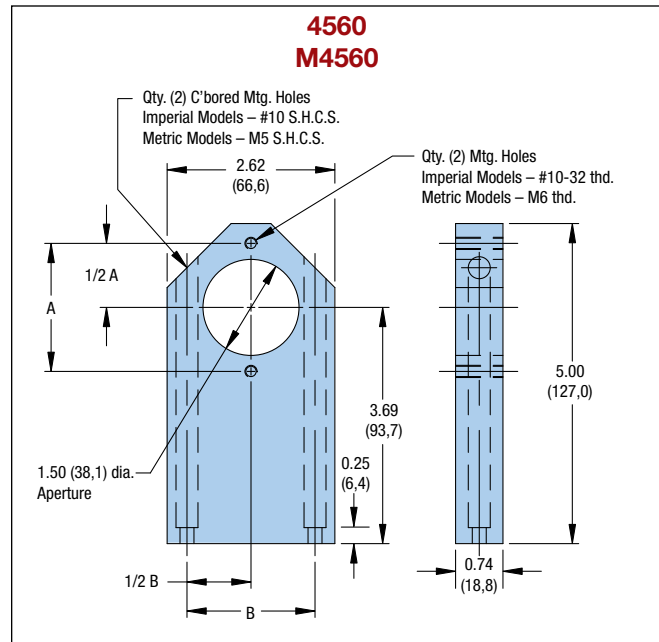

		Dimensions - in (mm)	
	Model	A	B
Imperial	4560	2.00	2.00
Metric	M4560	(50,0)	(50,0)

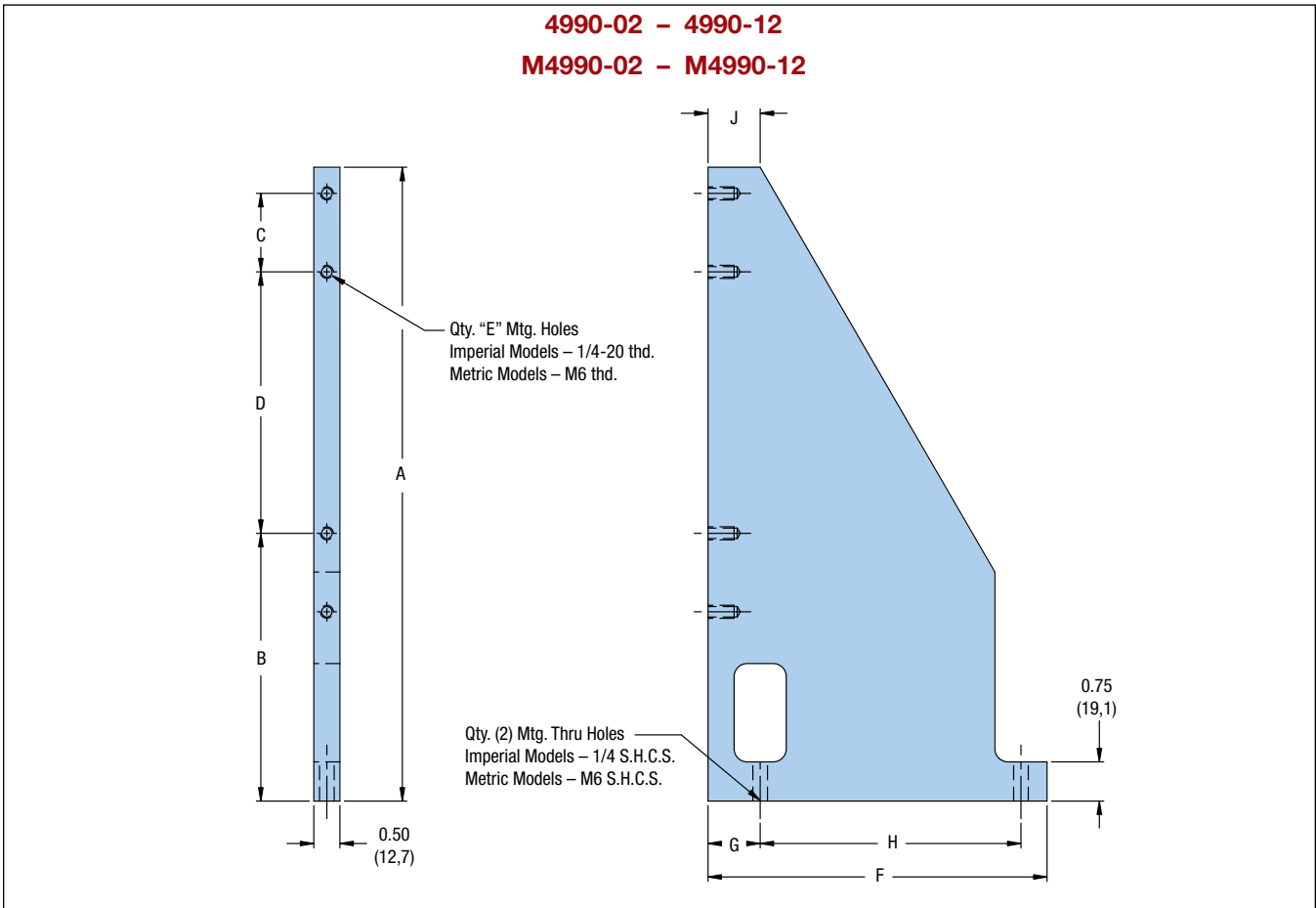

		Dimensions - in (mm)									
	Model	A	B	C	D	E	F	G	H	J	
Imperial	4990-02	6.00	1.50	-	4.00	2	5.50	1.00	4.00	1.00	
	4990-04	8.12	2.62	-	5.00	2	6.50	1.00	5.00	1.00	
	4990-06	12.12	5.12	1.5	5.00	4	6.50	1.00	5.00	1.00	
	4990-08	17.12	8.62	3.0	5.00	4	6.75	1.25	5.00	1.50	
	4990-10	20.50	10.00	4.0	6.00	4	6.75	1.25	5.00	1.50	
	4990-12	24.12	11.62	5.0	7.00	4	6.50	1.00	5.00	1.00	
Metric	M4990-02	(152,4)	(38,9)	-	(100,0)	2	(139,7)	(26,2)	(100,0)	(25,4)	
	M4990-04	(206,2)	(67,6)	-	(125,0)	2	(165,1)	(26,4)	(125,0)	(25,4)	
	M4990-06	(307,8)	(131,2)	(37,5)	(125,0)	4	(165,1)	(26,4)	(125,0)	(25,4)	
	M4990-08	(434,8)	(220,0)	(75,0)	(125,0)	4	(171,5)	(32,8)	(125,0)	(38,1)	
	M4990-10	(520,7)	(255,2)	(100,0)	(150,0)	4	(171,5)	(32,8)	(125,0)	(38,1)	
	M4990-12	(612,6)	(296,6)	(125,0)	(175,0)	4	(171,5)	(32,8)	(125,0)	(38,1)	

9510-9530 Series Micrometer Heads

Parker Daedal micrometer heads are recommended for any application requiring micrometer accuracy in settings and adjustment. These units feature a hardened and ground spindle, easy-to-read graduations, and an attractive non-glare satin chrome finish.

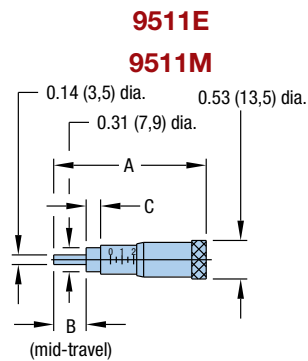

Figure A
Mini Thimble Micrometer Head

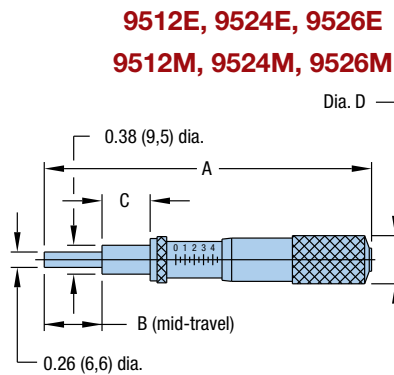

Figure B
Standard Thimble Micrometer Head

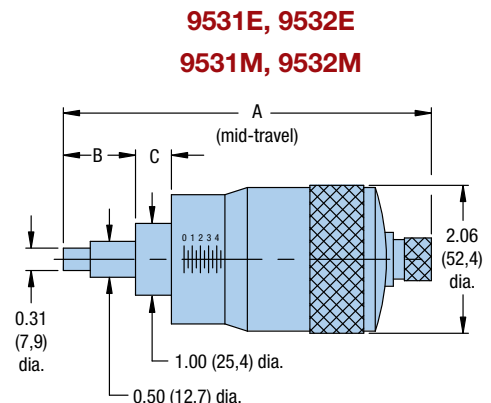

Figure C
Large Thimble Micrometer Head

		Model Number	Figure	Travel in (mm)	Graduations in (mm)	Dimensions – in (mm)			
						A	B	C	D
Imperial		9511E	A	0.50	0.001	2.03	0.50	0.187	—
		9512E	B	0.50	0.001	2.63	0.50	0.375	0.54
		9524E	B	1.00	0.001	4,23	0.75	0.625	0.73
		9526E	B	2.00	0.001	6.16	1.25	0.625	0.73
		9531E	C	1.00	0.0001	5.18	0.94	0.56	—
		9532E	C	2.00	0.0001	7.18	1.44	0.56	—
Metric		9511M	A	(13)	(0,01)	(51,6)	(13,0)	(4,7)	—
		9512M	B	(13)	(0,01)	(66,8)	(13,0)	(9,5)	(13,7)
		9524M	B	(25)	(0,01)	(107,4)	(19,0)	(15,9)	(18,5)
		9526M	B	(50)	(0,01)	(156,5)	(32,0)	(15,9)	(18,5)
		9531M	C	(25)	(0,002)	(131,6)	(23,9)	(14,2)	—
		9532M	C	(50)	(0,002)	(182,4)	(36,6)	(14,2)	—



9550 Series Digital Micrometer Heads

Model 9551

The 9551 precision electronic digital micrometer head provides an LCD readout to 0.00005 inch resolution. The micrometer features:

- Incremental and/or absolute positioning modes
- Zero set at any position, inch and millimeter readout (0.001 mm resolution), display hold, and automatic shutdown after two hours to conserve the integral battery
- 1.00 inch micrometer travel
- Battery powered for 500 hours of use

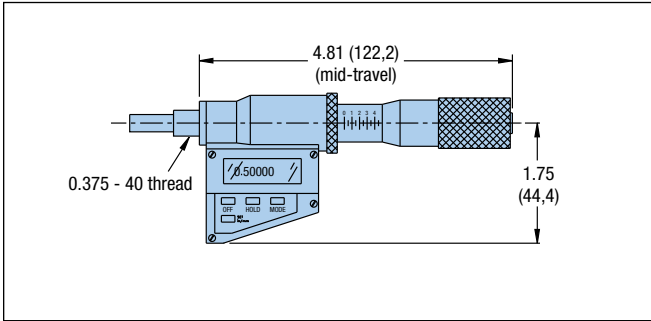

Model 9552

The 9552 precision electronic digital micrometer offers a 0 – 2 inch travel range with a 0.00005 inch resolution. Features include:

- 2 inch spindle
- Display face swivels for easy reading at various angles
- Non-rotating spindle
- Pre-set, zero, and inch/mm
- Carbide tipped measuring face
- Battery powered for 5,000 hours of use

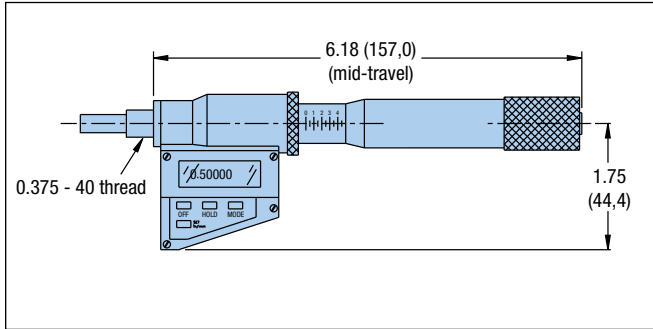

9560 Series Differential Screws

Model 9560: 0.75 in Range

The 9560 differential screw offers two linear adjustment ranges in one unit: a coarse adjustment range of 0.31 in (8 mm) with a 48-pitch thread and a fine adjustment range of 0.078 in (2 mm) with a pitch equal to 336 threads per inch. The 9560 is interchangeable with 9511 – 9532 series micrometer heads.

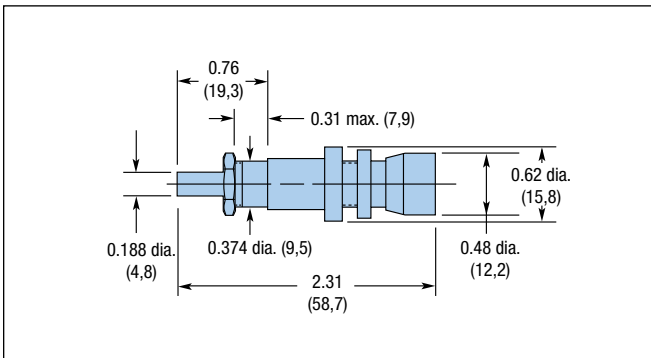

9570 Series Fine Adjustment Screws

Model 9570: 0.75 in Range

Model 9575: 0.50 in Range

These steel adjustment screws feature a 64-pitch thread, making them ideal for applications where finer resolution is required, but positional readout is not. These screws are easily interchanged with the 9511 – 9532 series micrometer heads.

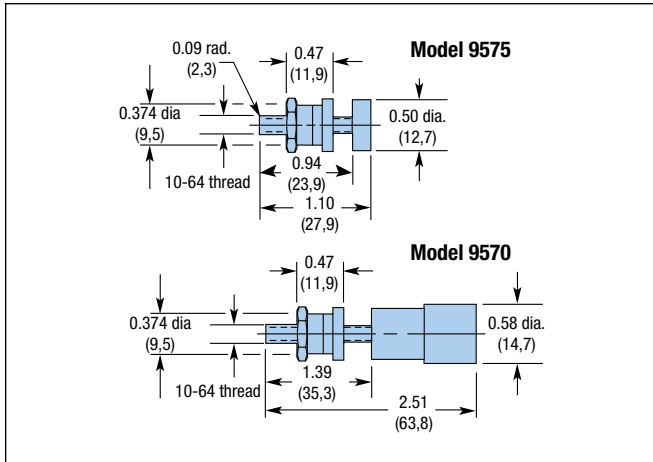

Optical Cell Mounts

Model 2350: 6.0” Diameter

Model 2355: 7.0” Diameter

Model 2360: 8.0” Diameter

Model 2365: 9.0” Diameter

Parker Daedal optical mounts are highly stable, adjustable mounts for optics up to 9” in diameter and 1.25” thick. These mounts feature precise kinematic ball pivot adjustment on two axes, with orthogonal three-point suspension.

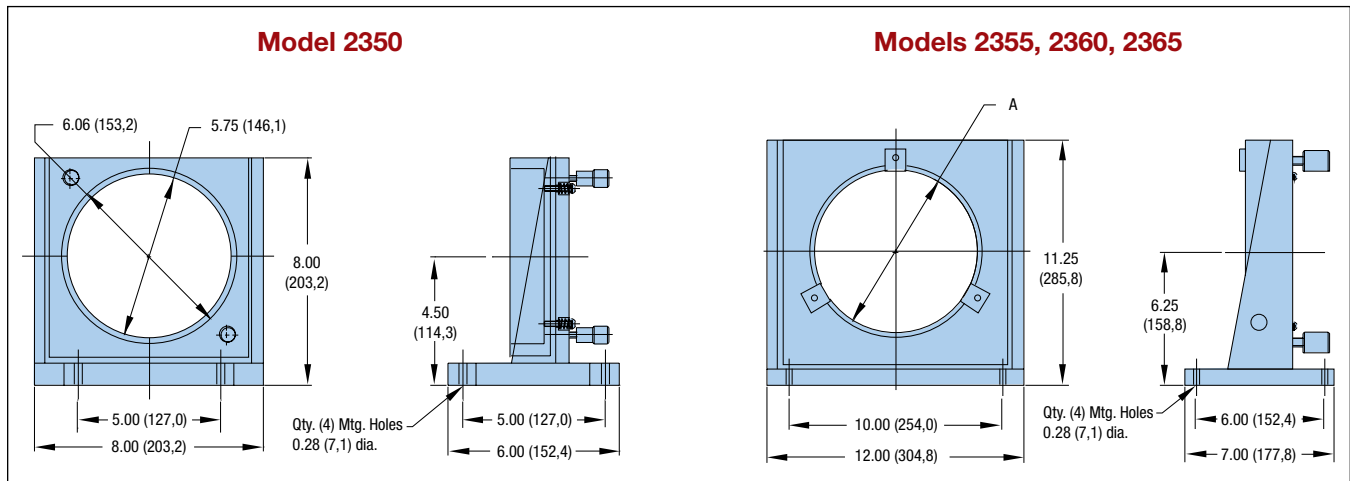

Specifications	2350	2355	2360	2365
Optic Size Opening – in (mm)				
Dimension “A” Dia. max.:	6.03 (153,1)	7.06 (179,3)	8.06 (204,7)	9.06 (230,1)
Thickness:	1.00 (25,4)	1.25 (31,75)	1.25 (31,7)	1.25 (31,7)
Optic Retention:	Threaded retainer	3 mounting clips	3 mounting clips	3 mounting clips
Range:	5°	5°	5°	5°
Resolution:	0.5 arc-sec	0.5 arc-sec	0.5 arc-sec	0.5 arc-sec
Adjustment:	2 – 64-pitch screws	3 – 32-pitch screws	3 – 32-pitch screws	3 – 32-pitch screws
Weight:	7.5 lb (16,5 kg)	20 lb (44 kg)	20 lb (44 kg)	20 lb (44 kg)
Construction:	Aluminum/stainless steel			
Finish:	Black anodize			



Optical Cell Mounts

Model 2370/2371: 10.0" Diameter

Model 2375/2376: 11.0" Diameter

Model 2380/2381: 12.0" Diameter

Parker Daedal optical mounts are highly stable, adjustable mounts for optics up to 12" in diameter and 2.0" thick. These mounts feature precise kinematic ball pivot adjustment on two axes, with orthogonal three-point suspension. Solid back models are designed to support reflective optics.

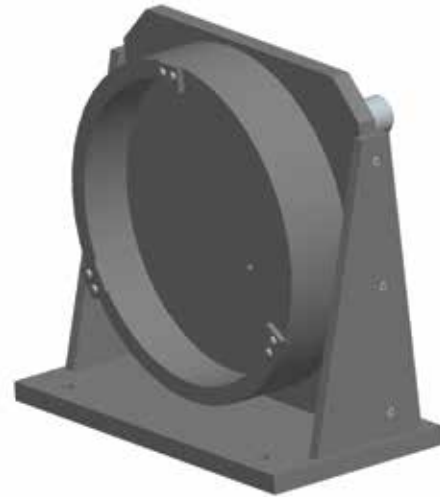

Crossed Roller Slides

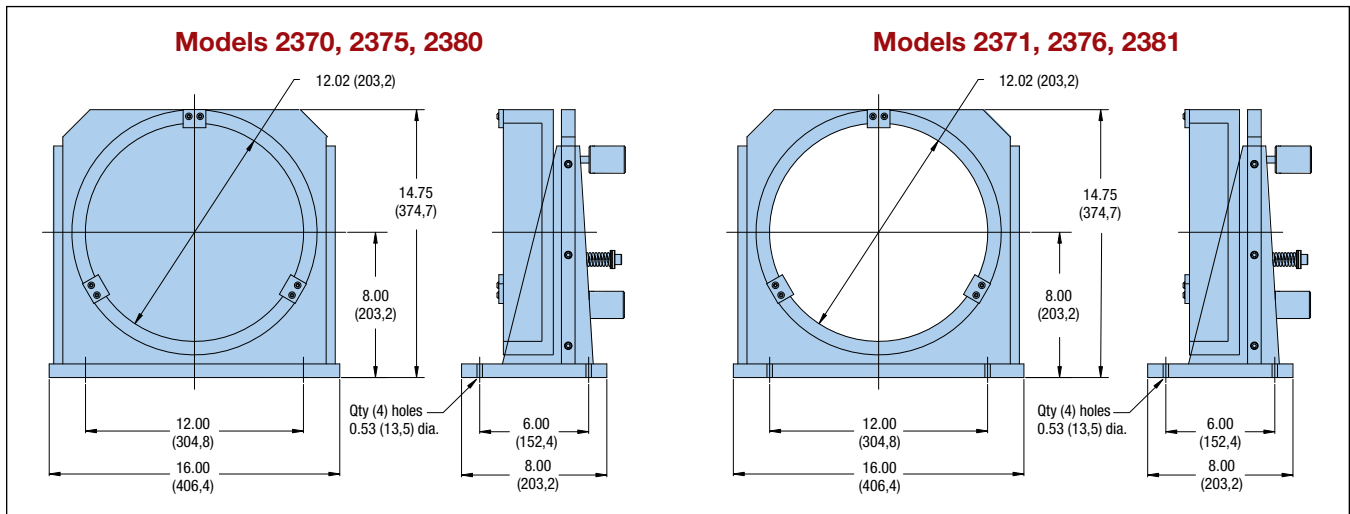

Specifications	Solid Back Models			Aperture Models		
	2370	2375	2380	2371	2376	2381
Optic Size Opening – in (mm)						
Dimension “A” Dia. max.:	10.02 (254,5)	11.02 (379,9)	12.02 (305,3)	10.06 (255,5)	11.06 (280,9)	12.06 (306,3)
Thickness:	2.00 (50,8)	2.00 (50,8)	2.00 (50,8)	2.00 (50,8)	2.00 (50,8)	2.00 (50,8)
Optic Retention:	3 mounting clips			3 mounting clips		
Range:	7°			7°		
Resolution:	0.5 arc-sec			0.5 arc-sec		
Adjustment:	3 – 32-pitch screws			3 – 32-pitch screws		
Weight:	45 lb (99 kg)			41 lb (90 kg)		
Construction:	Aluminum/stainless steel			Aluminum/stainless steel		
Finish:	Black anodize			Black anodize		

Mirror Mounts

Model 5000/5100: 3.0" Square Mounting Surface

Model 5300/5700: 4.5" Square Mounting Surface

Model 5800/5900: 6.0" Square Mounting Surface

Parker Daedal mirror mounts are patterned with 1/4-20 holes on 0.5" or 1.0" centers to mount mirrors and other hardware. All models except the 5800 have two fine resolution 64-pitch adjustment screws to provide precise tilting of the mounting surface in two axes. The 5800 is equipped with three adjustment screws to provide precise tilting in two axes.

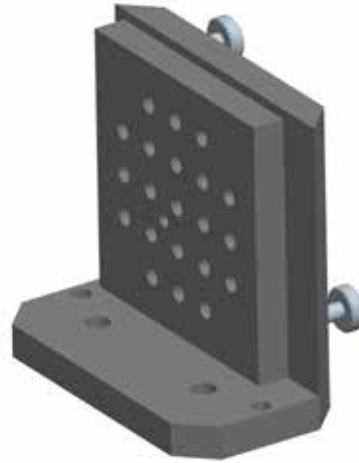

Specifications	Angled Base Models			Flat Base Models		
	5000	5300	5800	5100	5700	5900
Mounting Surface						
Size (Square) – in (mm)	3.0 (76,2)	4.5 (114,3)	6.0 (152,4)	3.0 (76,2)	4.5 (114,3)	6.0 (152,4)
Holes – (Qty. x Center)	21 x 0.50"	49 x 0.50"	25 x 1.0"	21 x 0.50"	49 x 0.50"	25 x 1.0"
Range:	12°	8°	4°	12°	8°	4°
Resolution:	1.0 arc-sec	0.75 arc-sec	0.5 arc-sec	1.0 arc-sec	0.75 arc-sec	0.5 arc-sec
Weight – lb (kg)	1 (2,2)	2 (4,4)	4.1 (9)	0.7 (1,5)	1.6 (3,5)	3 (6,6)
Adjustment:	2 – 64-pitch screws (3 screws on 5800)			2 – 64-pitch screws		
Construction:	Aluminum/stainless steel			Aluminum/stainless steel		
Finish:	Black anodize			Black anodize		

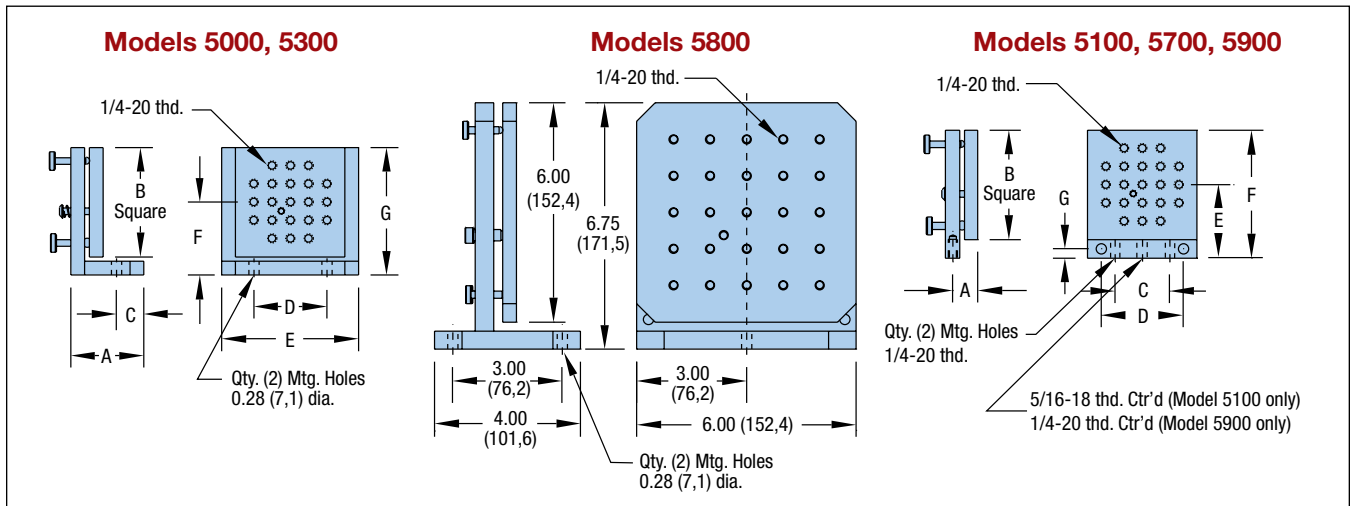

Model	Dimensions – in (mm)						
	A	B	D	D	E	F	G
5000	2.00 (50,8)	3.00 (76,2)	0.75 (19,1)	2.00 (50,8)	3.75 (95,3)	2.00 (50,8)	3.50 (88,9)
5300	3.00 (76,2)	4.50 (114,3)	1.25 (31,8)	4.00 (101,6)	4.50 (114,3)	2.88 (73,2)	5.12 (130,1)
5100	0.69 (17,5)	3.00 (76,2)	1.50 (38,1)	2.25 (57,2)	2.00 (50,8)	3.50 (88,9)	0.25 (6,4)
5700	0.69 (17,5)	4.50 (114,3)	3.00 (76,2)	3.75 (95,3)	2.88 (73,2)	5.12 (130,1)	0.25 (6,4)
5900	0.88 (2,4)	6.00 (152,4)	4.00 (101,6)	5.38 (136,7)	3.25 (82,6)	6.25 (158,8)	0.31 (7,9)

Travel

The travel listed is the total travel of the positioner from hard stop to hard stop.

Bearing Load Capacity

Normal Load

This is the maximum downward (compression) load or force which can be applied to the positioner perpendicular to the mounting surface. The center of force or the C.G. of the load must be located in the center of the mounting surface. For loads which are offset from this position, refer to moment loads.

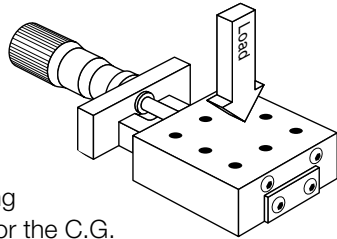

Inverted Load

Same as a normal load except in an upward (tension) direction.

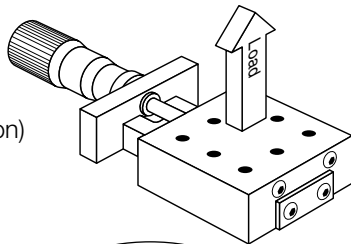

Moment Load

This refers to forces which are offset (cantilevered) from the bearing centers and therefore producing uneven loading on the bearings. This uneven loading means that some bearings are supporting more of the load than others. For this reason it is very important to determine if the moment loading for a given positioner is within acceptable limits. These moment forces are categorized by the direction they act in Pitch, Roll or Yaw; see diagram at left. When loading results in moments acting in only one of the moment directions (pitch, roll or yaw) it is called a single direction moment. Examples of this type of loading are shown below. How to calculate the maximum allowable moment load is discussed on the following page.

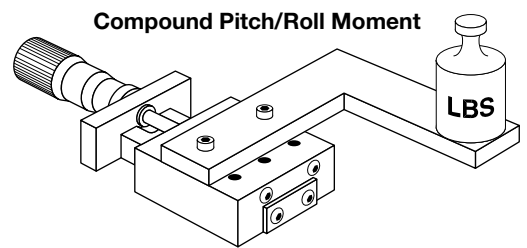
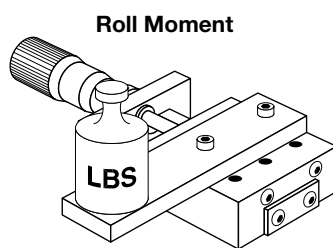
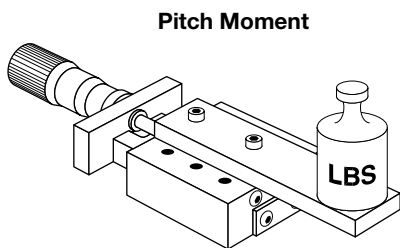
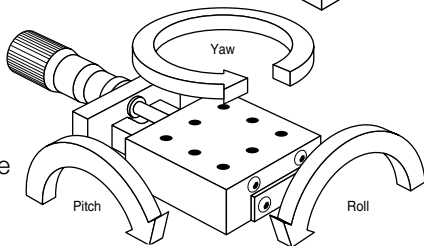

Thrust Capacity

Thrust capacity is the maximum force or load which can be applied in the direction of travel without damage to positioning stage components.

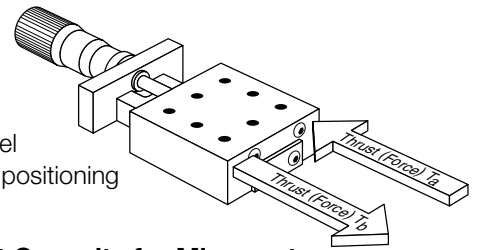

T_a and T_b Thrust Capacity for Micrometer, Fine Screw and Differential Screw Drives

With these types of drives the mounting surface or stage carriage is pressed against the drive mechanism by means of a spring. Because of this the maximum thrust which the stage assembly can maintain is different when pressing toward the spring or away from it. When pressing toward the spring, the force is taken up by the drive mechanism (i.e. micrometer). While pulling away, the force is being held in place by the spring. Stages with this type of mechanism have two thrust capacity specifications (T_a and T_b). T_a refers to the load capacity against the micrometer and T_b is the spring load capacity. Refer to specific product drawings for load direction.

Screw Drive Thrust Capacity

Stages which use screw drive assemblies will only have one thrust capacity rating. This rating is for either direction of travel.

Straight Line and Flatness Accuracy

This is the amount of error a linear positioner deviates from an ideal straight line. The straight line accuracy is the error in the horizontal plane while flatness is the error in the vertical plane. Both the straight line and the flatness accuracy are measured at the moving carriage surface center.

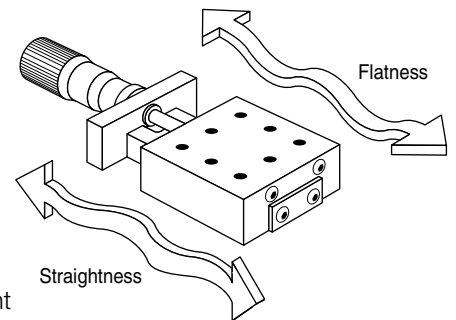

Calculating Maximum Allowable Moment Loads on Linear Slides and Stages

To determine if a load or force is within acceptable moment load ranges follow the steps below:

1. Calculate maximum load and or force which will be applied to the positioner. Include brackets and other axes which are mounted to the positioner.
2. Locate the center of gravity of the load.
3. Determine if there is a single or compound moment.
4. Measure the distance from the center of force or C.G. to the center of the linear stage carriage. This is the moment arm length and is designated A_S for single direction moments and A_C for compound moments.
5. Locate the moment load graph for the positioner you are interested in (located in back of individual product section, see example below). The X axis of the graph is the Force, the Y axis is the allowable moment arm A_S for single direction moments.
6. Locate the moment curve(s) which your load is acting in (pitch, roll or yaw).
7. Locate your load force on the X axis of the graph.
8. Draw a vertical line from the Force location on the X axis parallel with the Y axis.
9. Find the moment arm distance on the Y axis. Draw a horizontal line from this point parallel with the X axis until the vertical and horizontal lines intersect.
10. If the intersection point is below the moment curve in question then the stage is within acceptable limits. If the intersection point is above the moment curve, a positioner with a larger normal load capacity should be selected and the above steps repeated.

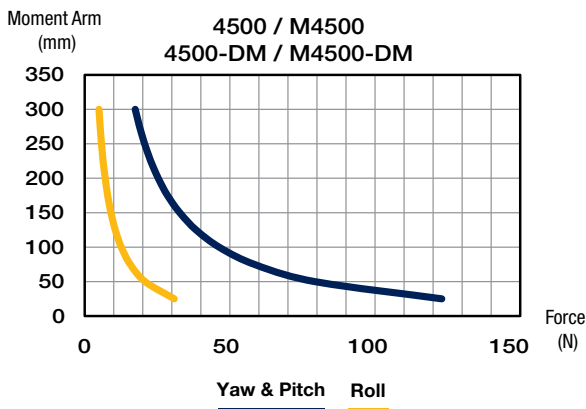

Example #1: Single Direction Moment Load

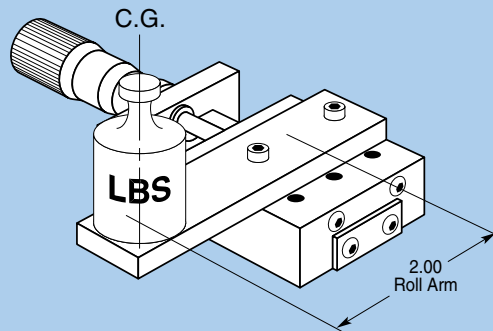

A 2 pound load is mounted to a single axis linear stage. The diagram shows the load's position in reference to the positioner carriage center. This shows that the load is offset 2 inches from the carriage center creating a roll moment.

The selected positioner is a 4502 ball stage. (The moment load curve for the 4502 is shown below.) First, find 2 pounds on the X axis and draw a vertical line. Next, draw a horizontal line starting at the 2 inches position on the A_S axis (single direction moment). Mark the intersection point.

In this example the intersection point is below the roll moment curve, indicating that the stage is acceptable for this application.

